

# MD 820 Chain Series

Straight Running-Single Hinge Chains



## MD 820 Technical Information

MD 820 SERIES STRAIGHT RUNNING - SINGLE HINGE CHAINS						
PRODUCT CODE	WIDTH (W)		PLATE THICKNESS (S)	TENSILE STRENGTH		WEIGHT
	mm	inch	mm	Kg/m	N/m	Kg/m
MD 820-K325-LF	82,5	3,25	4	140	1400	0,84
MD 820-K400-LF	101,6	4,00	4	140	1400	0,95
MD 820-K450-LF	114,3	4,50	4	140	1400	1,05
MD 820-K600-LF	152,4	6,00	4,8	140	1400	1,30
MD 820-K750-LF	190,5	7,50	4,8	140	1400	1,55

\* Selflubricating low friction acetal resin, brown-coloured.

\* Pins in special chrome-nickel 304 stainless steel

\* Standard packing lengths = 80 pitches = 3,048 m

## MD 820 Technical Drawings

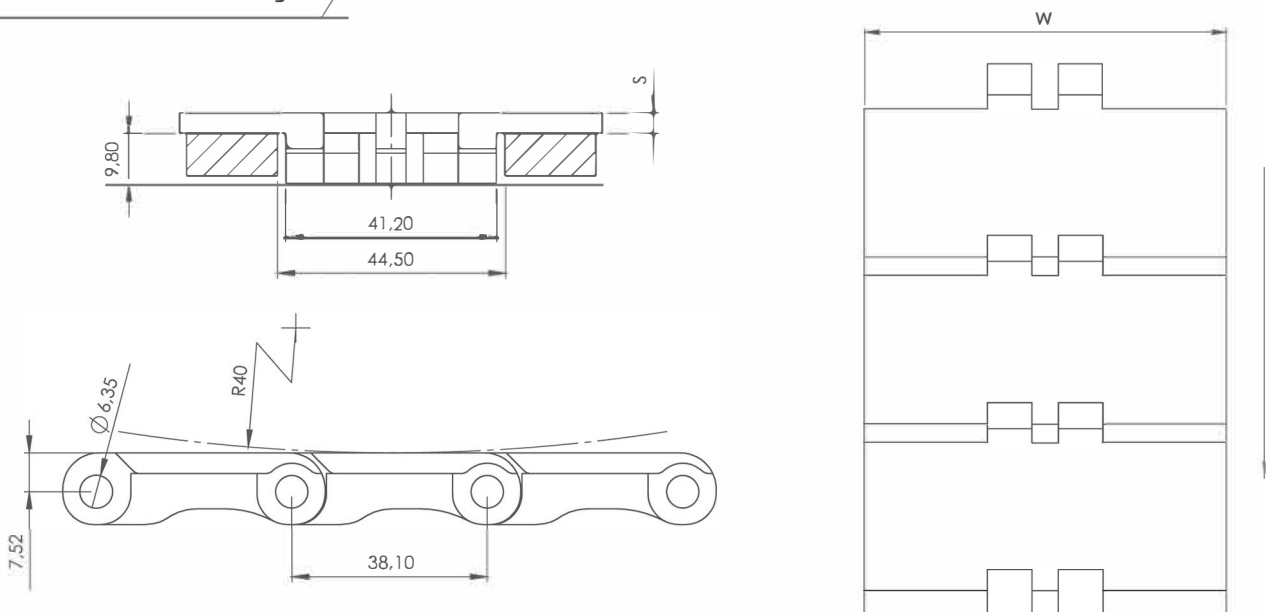

# Sprockets

## MD 820 Sprockets Technical Drawings

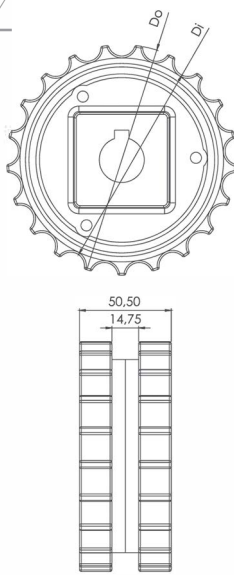

Classic Sprocket Series MD820				
Product Code	Number of Teeth	Do (mm)	Di (mm)	Round Bore (Ø)
MD 820	21	128	114	25 30
MD 820	25	152	138	25 30

\* Special sprockets and hub size are being manufactured on your request.

## MD 880 Sprockets Technical Drawings

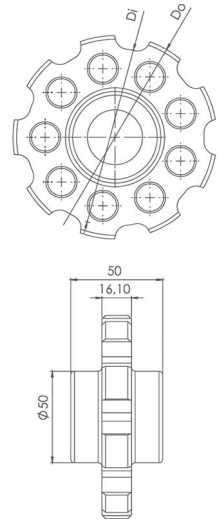

Classic Sprocket Series MD880				
Product Code	Number of Teeth	Do (mm)	Di (mm)	Round Bore (Ø)
MD 880	9	111	97	25 30
MD 880	11	135	121	25 30

\* Special sprockets and hub size are being manufactured on your request.

## MD 1701 R Sprockets Technical Drawings

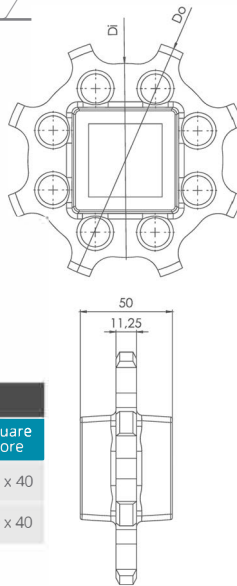

Classic Sprockets Series MD1701					
Product Code	Number of Teeth	Do (mm)	Di (mm)	Round Bore (Ø)	Square Bore
MD 1701 R	8	132	107	25 30	40 x 40
MD 1701 R	10	166	107	25 30	40 x 40

\* Special sprockets and hub size are being manufactured on your request.

## Flexi Chains Sprocket Technical Drawings

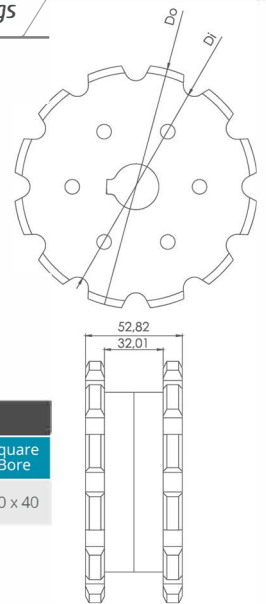

Classic Sprockets Series Flexi Chains					
Product Code	Number of Teeth	Do (mm)	Di (mm)	Round Bore (Ø)	Square Bore
FLEXI CHAIN	12	133	115	25 30	40 x 40

\* Special sprockets and hub size are being manufactured on your request.

## MD 600 S Sprockets Technical Drawings

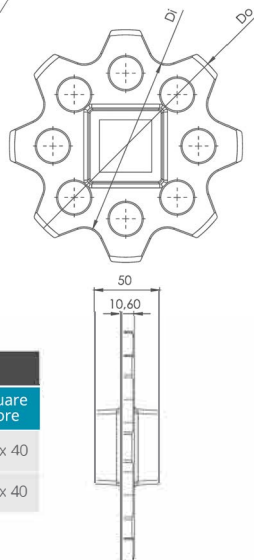

Classic Sprockets Series MD600					
Product Code	Number of Teeth	Do (mm)	Di (mm)	Round Bore (Ø)	Square Bore
MD 600	8	177	138	25 30	40 x 40
MD 600	10	221	176	25 30	40 x 40

\* Special sprockets and hub size are being manufactured on your request.